

Towing hitch accessories:

Pos. 1 Main bar PCS.: 1	Pos. 5 Bolt 8,8 B M12x70mm PCS.: 1	Pos. 10 Spring washer ø12mm PCS.: 2
	Pos. 6 Bolt 8,8 B M10x35mm PCS.: 4	Pos. 11 Spring washer ø10mm PCS.: 4
Pos. 2 Tow ball PCS.: 1	Pos. 7 Nut 8 B M12 PCS.: 2	Pos. 12 Ball cover PCS.: 1
Pos. 3 Socket plate PCS.: 1	Pos. 8 Plain washer ø12mm PCS.: 2	
Pos. 4 Bolt 8,8 B M12x75mm PCS.: 1	Pos. 9 Plain washer ø30xø10.5x2.5mm PCS.: 4	



PPUH AUTO-HAK Sp.J.

Produkcja Zaczepów Kulowych
Henryk & Zbigniew Nejman
76-200 SŁUPSK ul. Słoneczna 16K
tel/fax (059) 8-414-414; 8-414-413
E-mail: office@autohak.com.pl
www.autohak.com.pl

Towing hitch (without electrical set)

Class: **A50-X** Cat. no. **A24**

Designed for:

Manufacturer: **AUDI**

Model: **A3**

Type: **3/5 doors, Sportback**

produced since 07.2008

Technical data:

D-value: 9,7 kN

maximum trailer weight: **1800 kg**

maximum vertical cup mass: **100 kg**

Approval number according to Directive 94/20/EC: e20*94/20*0746*00

Foreword

This towing hitch is designed according to rules of safety traffic regulations. The towing hitch is a safety component and can be install only by qualified personnel. Any alteration or conversion of the towing hitch is prohibited and would lead to cancellation of design certification. Remove insulating compound and underseal from vehicle (if present) in the area of the matting surfaces of the towing hitch. The vehicle manufacturer's specifications regarding trailer mass and max. vertical cup mass are decisive for driving whereat values for the towing hitch cannot be exceeded.

D-value formula:

$$\frac{\text{Max trailer weight [kg]} \times \text{Max vehicle weight [kg]}}{\text{Max trailer weight [kg]} + \text{Max vehicle weight [kg]}} \times \frac{9,81}{1000} = D \text{ [kN]}$$

FITTING INSTRUCTION

Clamp mark in acc. with		Cables joining
ISO	PN	
1	L	Left directional lights
2	+	Rear fog lights
3	31	Ground
4	R	Right directional lights
5	58R	Right side parking lights
6	54	Stoptlights
7	58L	Left side parking lights

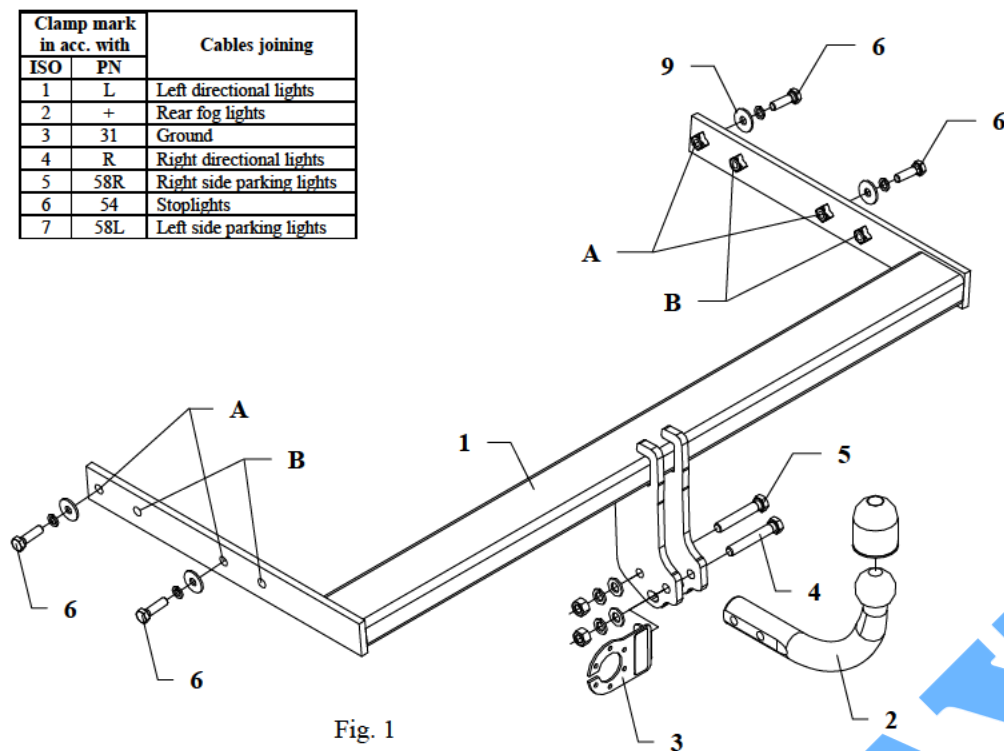

Fig. 1

This towing hitch is designed to assembly in following cars: **AUDI A3, 3/5 doors, SPORTBACK** produced since 07.2008, catalogue no. A24 and is prepared to tow trailers max total weight **1800 kg** and max vertical mass **100 kg**.

Torque settings for nuts and bolts (8,8).

M6 - 11 Nm	M 8 - 25 Nm	M 10 - 50 Nm
M 12 - 87 Nm	M 14 - 138 Nm	M16 - 210 Nm

From manufacturer

Thank you for buying our product. Their reliability has been confirmed in many tests. Reliability of towing hitch depends also on correct assembly and right operation. For this reasons we kindly ask to read carefully this instruction and apply to hints.

The towing hitch should be install in points described by a car producer.

The instruction of the assembly

1. Disassemble the rear-light units.
2. Disassemble the bumper with its metal reinforcement. The metal reinforcement will not be assembled again.
3. Fix again bolts fastening reinforcement.
4. Slip the main bar of the towing hitch (pos. 1) to chassis members in that way so holes of the towing hitch be covered with existing holes in chassis members and fix using bolts M10x35mm (pos. 6) as it shown on drawing:
 - through holes A for 5 doors version,
 - through holes B for 3 doors version.
5. Install the bumper after cut out of its fragment (see fig. 2 and 3).
6. Fix tow ball (pos. 2) using bolt M12x75mm (pos. 4) and M12x70mm (pos. 5). With bolt M12x75mm fix also a socket plate (pos. 3). See figure 1.
7. Tighten all bolts according to the torque shown in the table.
8. Reassemble the rear-light units.
9. Connect electric wires of 7-poles socket according to the instruction of the car. (Recommend to make at authorized service station).
10. Complete paint layer damaged during installation.

NOTE

After install the towing hitch you should get adequate note in registration book (at authorised service station). The car should be equipped with:

- Indicators
- Tow mirrors

After 1000km check all bolts and nuts. The ball of towing hitch must be always kept clear and conserve with a grease.

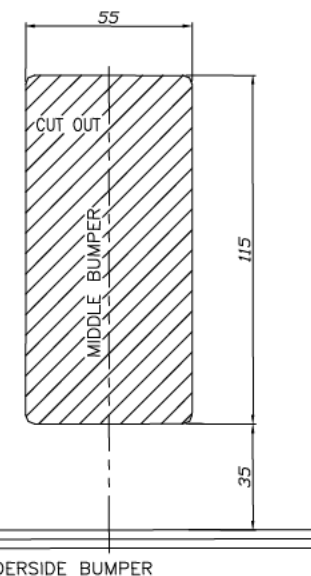

UNDERSIDE BUMPER

Fig. 2 Sample for 3 doors version

Fig. 3 Sample for 5 doors version

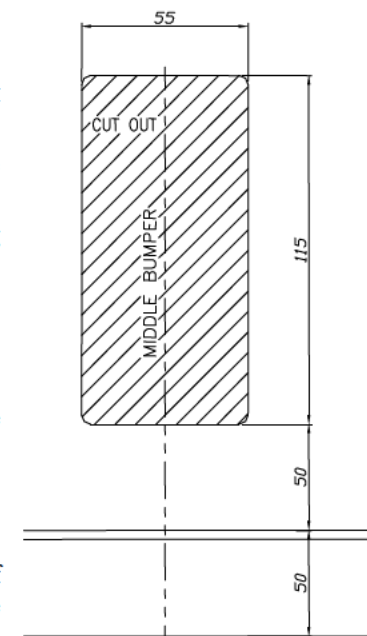

UNDERSIDE BUMPER